

# Stainless steel pressure reducing valve flange type DM13 | DM20

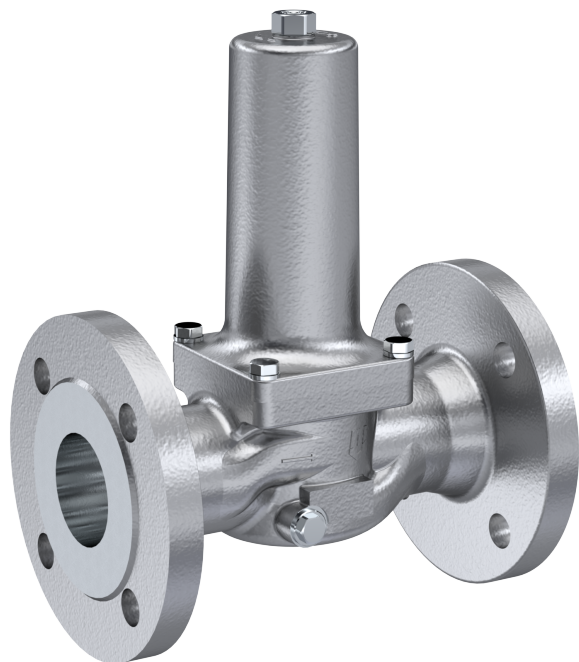

**Description:**

Stainless steel pressure reducing valves are used to regulate the supply pressure in a system, to compensate for different inlet pressures to a certain pressure in the outlet side.

**Features:**

- suitable for aggressive water and other aggressive fluids
- **suitable for air & neutral non-inflammable gases**
- industrial design – full metal
- with cast flanges
- Built-in dirt trap and 1 manometer connection G 1/4" inch axial
- mounting position: any

**Connection:**

DN15, DN20, DN25, DN32, DN40, DN50, DN65, DN80, DN100

**Temperature:**

-20°C to +190°C

Depending on design

**Pressure:**

Inlet pressure: to 40,0 bar

Outlet pressure: 0,2 bar – 9,0 bar

Depending on design

Subject to PED 2014/68/EU category I

**Design:**

Piston pressure reducing valve with built-in dirt trap

**Body:**

Stainless steel 1.4408

**Flanges:**

Stainless steel 1.4408

**Spring bonnet:**

Stainless steel 1.4408

**membrane / seal:**

|                 |                    |                 |
|-----------------|--------------------|-----------------|
| <b>TYP DM13</b> | FKM / FPM          | -10°C to +190°C |
| <b>TYP DM20</b> | EPDM (FDA konform) | -20°C to +120°C |

**Internals:**

Stainless steel 1.4404

**Assembly position:**

any, preferably vertical

**Connection:**

Flange acc. to DIN EN 1092 PN40, PN25, PN16 or ANSI 150

**Pressure range:**

|           | <b>Outlet pressure</b> | <b>Inlet pressure</b> |
|-----------|------------------------|-----------------------|
| spring 00 | 1,5 to 6,0 bar         | to 40,0 bar           |
| spring 01 | 0,2 to 2,0 bar         | to 25,0 bar           |
| spring 02 | 0,5 to 9,0 bar         | to 40,0 bar           |

**Minimum pressure difference:**

Inlet-/outlet pressure 1 bar

**Note:**

Type DM20 with EPDM seal comes with FDA-conformity, therefor it can be used for food-applications.

**Dimensions:**

| <b>Diameter DN</b>   | <b>15</b> | <b>20</b> | <b>25</b> | <b>32</b> | <b>40</b> | <b>50</b> | <b>65</b> | <b>80</b> | <b>100</b> |
|--|-----------|-----------|-----------|-----------|-----------|-----------|-----------|-----------|------------|
| Flange DIN EN 1092   | PN40      | PN40      | PN40      | PN40      | PN40      | PN40      | PN25      | PN25      | PN16       |
| <b>Outlet pressure 1,5 up to 6,0 bar and outlet pressure 0,5 up to 9,0 bar</b> |           |           |           |           |           |           |           |           |            |
| b in mm  | 130       | 150       | 160       | 180       | 200       | 230       | 290       | 310       | 350        |
| D in mm  | 95        | 105       | 115       | 140       | 150       | 165       | 185       | 200       | 220        |
| h1 in mm   | 48        | 53        | 58        | 70        | 75        | 83        | 127       | 127       | 127        |
| h in mm  | 116       | 116       | 116       | 116       | 219       | 219       | 347       | 347       | 347        |
| Kvs-value m3/h   | 2,9       | 3,9       | 5,4       | 6,1       | 9,0       | 13,0      | 48,0      | 60,0      | 70,0       |
| weight in kg   | 2,9       | 3,6       | 4,9       | 6,2       | 9,8       | 11,6      | 32,0      | 34,9      | 35,9       |
| <b>Outlet pressure 0,2 up to 2,0 bar</b>                                       |           |           |           |           |           |           |           |           |            |
| b in mm  | 130       | 150       | 160       | 180       | 200       | 230       | -         | -         | -          |
| D in mm  | 95        | 105       | 115       | 140       | 150       | 165       | -         | -         | -          |
| h1 in mm   | 48        | 53        | 58        | 70        | 75        | 83        | -         | -         | -          |
| h in mm  | 136       | 136       | 148       | 148       | 271       | 271       | -         | -         | -          |
| Kvs-value m3/h   | 2,9       | 3,9       | 5,4       | 6,1       | 9,0       | 13,0      | -         | -         | -          |
| Weight in kg   | 3,3       | 4,0       | 5,9       | 7,2       | 13,5      | 15,3      | -         | -         | -          |

**Outlet pressure 1,5 up to 6,0 bar and outlet pressure 0,5 up to 9,0 bar:**

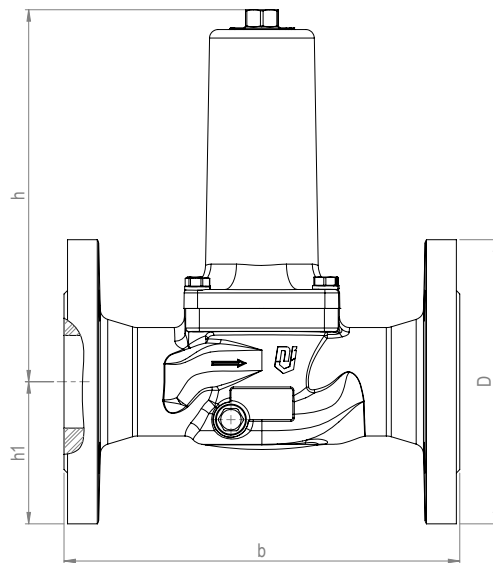
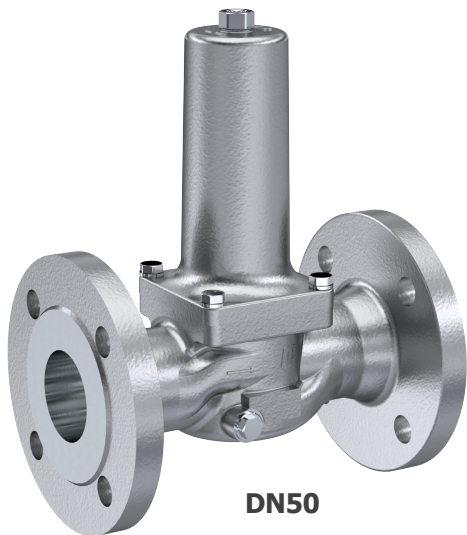

**Outlet pressure 0,2 up to 2,0 bar:**

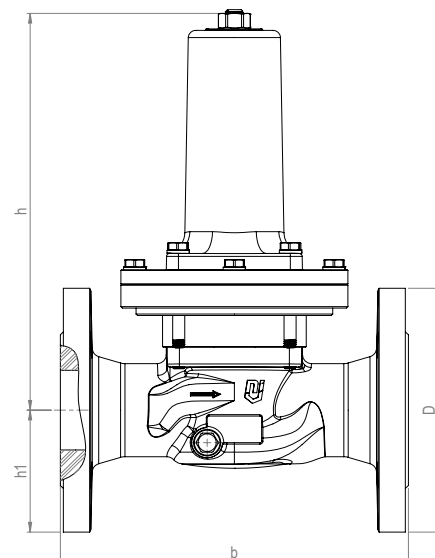
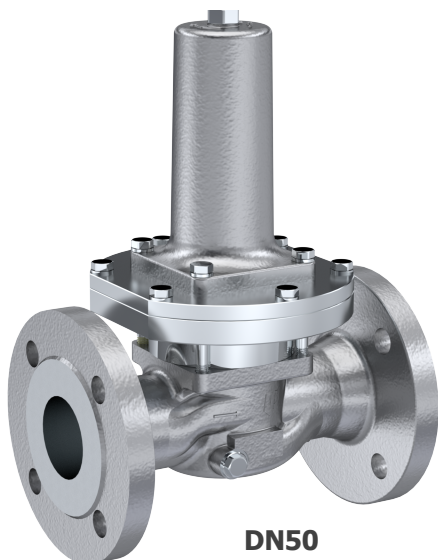

## Article number:

| Type                             | Outlet pressure   | Connection   | Size  |
|----------------------------------|---|--|---|
| <b>DM13</b> – FPM<br>DM20 – EPDM | <b>00</b> – 1.5 up to 6.0 bar<br>01 – 0.2 up to 2.0 bar<br>02 – 0.5 up to 9.0 bar | <b>00</b> – flange DIN EN 1092*<br>01 – flange ANSI150 | 03 – DN15<br>04 – DN20<br>05 – DN25<br>06 – DN32 (not available with EPDM)<br><b>07</b> – DN40<br>08 – DN50<br>09 – DN65**<br>10 – DN80**<br>11 – DN100** |

\*DN15-DN50 with flange PN40, DN65-DN80 with flange PN25 and DN100 with flange PN16

\*\*DM13 01 and DM20 01: DN65, DN80 and DN100 not available

### Example No. **DM13000007:**

**DM13** | **00** | **00** | **07**

Pressure reducing valve made of stainless steel

Outlet pressure: 1,5 up to 6,0 bar

Membrane: FPM

Connection: flange PN40

Size: DN40

Image similar, subject change without notice.