

Pneumatic gate valve TYPE SR03



Description:

Knife gate valve with pneumatic actuation made of stainless steel. Inteded for the automatic shut off of pipes of the heavy fluids like slurries and powders. Main fields of application: water treatment, paper industry and food industry.

Product features:

- Uni-directional thightness
- Pneumatic actuation
- Indoor and outdoor installation

Image: double acting actuator

Size:
DN50 – DN400

Design:
Uni-directional thightness

Pressure:
Up to 10,0 bar – depending on size

Design: Uni-directional thightness
Body: Stainless steel 1.4408
Gate: Stainless steel AISI 316
Packing: PTFE
Seat: EPDM
Support: Epoxy coated carbon steel
Flange: Acc. to DIN EN 1092-2 PN10
Temperature: EPDM 0°C to +110°C
Room temperature: -20°C to +60°C

Actuation: Double acting pneumatic actuation
Spring return actuator

Fluid: Use not allowed on group 1 dangerous gas for sizes > 100
Compressed air supply: Min. 5 bar – max. 7 bar
Air supply: Lubricated compressed air

Standards: P.E.D. CE 2014/38 – Category I module A

Max. working pressure:

DN	50	65	80	100	125	150	200	250	300	350	400
in bar	10	10	10	10	10	10	10	8	6	4	4

Actuation: double acting pneumatic

Optional: Actuator with manual override – on request

Dimensions:

DN	50	65	80	100	125	150	200	250	300	350	400
H2	63	70	92	105	120	130	160	198	234	256	292
H4	400	442	483	546	630	692	869	1032	1182	1379	1535
C	125	140	155	175	190	220	275	325	380	440	495
D	92	92	92	92	102	102	120	120	120	290	290
L	40	40	50	50	50	60	60	7	70	96	100
Ø K	125	145	160	180	210	240	295	350	400	460	515
Ø M	4 xM16	4 xM16	4 xM16	4 xM16	4 xM16	4 xM20	4 xM20	6 xM20	6 xM20	10xM20	10xM24
Kg	9	11	12	13	18	22	40	50	65	120	150

Pos.	Part	Material
1	Body	Epoxy coated cast iron EN-GJL 250
2	Gate	Stainless steel AISI 304
3	Stuffing's box gland DN50-200	Aluminium
3	Stuffing's box gland DN200-300	Cast iron EN-GJL 250
4	Seat	NBR or EPDM
5	Support	Epoxy coated carbon steel
6	Ring	Stainless steel AISI 304
7	Packing	PTFE
8	O-Ring	NBR or EPDM
9	Stem	Stainless steel AISI 304
10	Actuator	Aluminium

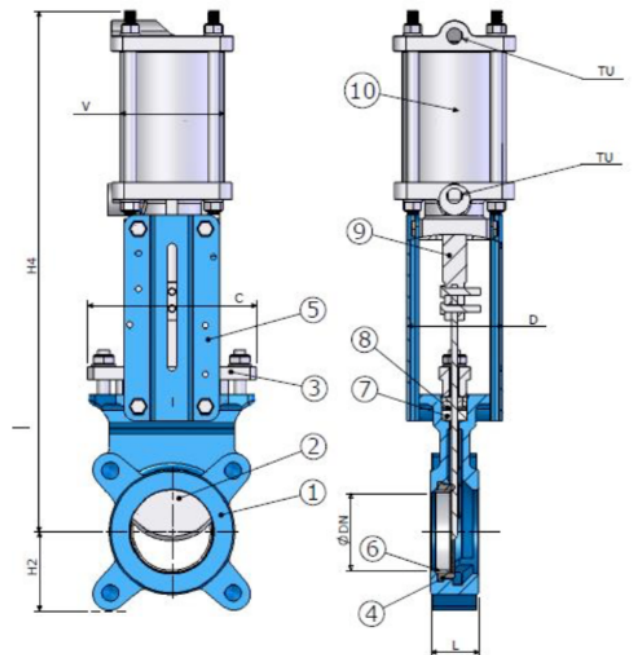

DN50-65

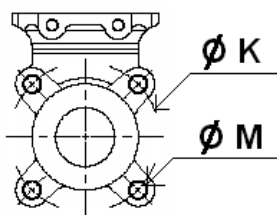

DN80-200

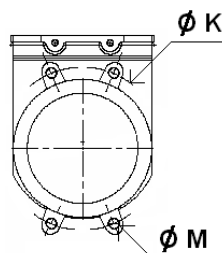

DN250-300

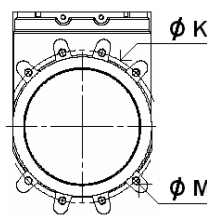

DN350

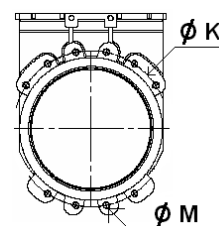

DN400

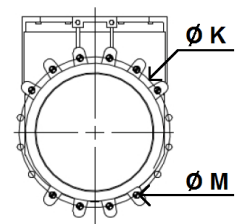

Air's ports:

DN50-DN300: G 1/4"
 DN350-DN400: G 3/8"

Actuation: Spring return actuator

Dimensions:

DN	50	65	80	100	125	150	200	250	300
A	40	40	50	50	50	60	60	70	70
B	92	92	92	92	102	102	119	119	119
C	63	70	92	105	120	130	160	198	234
F	125	140	155	175	190	220	175	325	380
W	720	766	810	875	975	1066	1380	1792	1932
N	96	96	96	115	138	138	175	218	218
Ø K	125	145	160	180	210	240	295	350	400
Ø M	4 xM16	4 xM16	4 xM16	4 xM16	4 xM16	4 xM20	4 xM20	6 xM20	6 xM20
Kg	9	11	12	13	18	22	40	50	65

Pos.	Part	Material
1	Body	Stainless steel 1.4408
2	Gate	Stainless steel AISI 316 SS
3	Stuffing's box gland DN50-200	Stainless steel 1.4408
3	Stuffing's box gland DN200-300	Stainless steel 1.4408
4	Seat	EPDM
5	Support	Steel
6	Ring	Stainless steel AISI 316 SS
7	Packing	PTFE
8	O-Ring	EPDM
9	Actuator	Aluminium

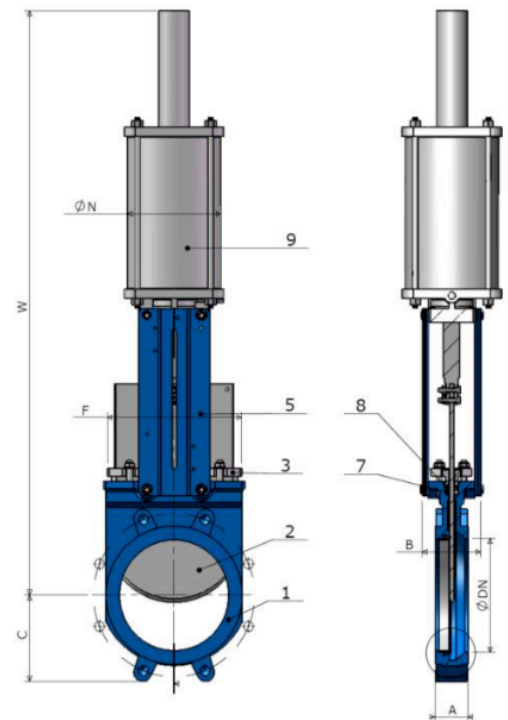

DN50-65

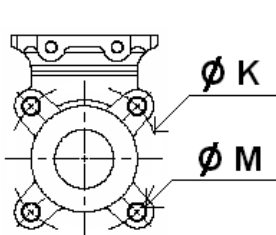

DN80-200

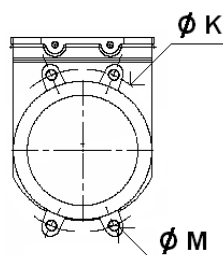

DN250-300

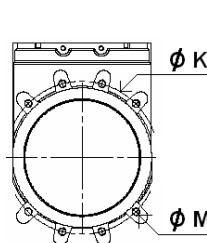

DN350

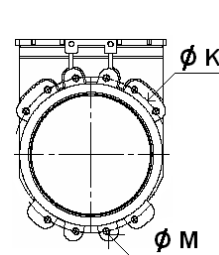

DN400

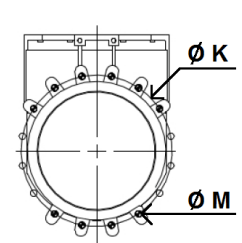

Article number:

Type	Seat	Actuation	Size
SR03	00 – EPDM	04 – double acting pneumatic actuator 05 – spring return actuator*	08 – DN50 09 – DN65 10 – DN80 11 – DN100 12 – DN125 13 – DN150 14 – DN200 15 – DN250 16 – DN300 17 – DN350 18 – DN400

Example Nr. SR03000411:

SR03 | **00** | **04** | **11**

Uni-directional knife gate valve
 Seat: NBR
 Actuation: double acting pneumatic actuator
 Size: DN100

* Available up to DN300

Image similar, subject change without notice.